

**Part Number: PT953-1M160-XX**

**Kit Contents**

Item #	Quantity Req.	Description
1	1	Lip Spoiler
2	2	M6 Flange Nut
3	2	M6 Serrated Flange Bolt
4	2	Torsion Bar Bracket

**Hardware Bag Contents**

Item #	Quantity Req.	Description
1		
2		
3		

**Additional Items Required For Installation**

Item #	Quantity Req.	Description
1	1	Installation Template P/N PT9531M160TL
2		
3		

**Conflicts**

None
------

**Recommended Tools**

<b>Personal &amp; Vehicle Protection</b>	<b>Notes</b>
Wrist & Belt Protectors	
Safety Glasses	
Shop Rags	
Masking Tape	
<b>Special Tools</b>	<b>Notes</b>
<b>Installation Tools</b>	<b>Notes</b>
Panel Fastener Removal Tool	
Center Punch	
Drill	
Drill Bits	3/8" and 23/64"
Drill Stop	3/8" and 23/64"
Deburring Tool	
1/4" Drive Ratchet	
Torque Wrench	0 to 100 in-lbf (0-10 N-m)
Socket	10mm
Deep Socket	10mm
Lint Free Cloth	
<b>Special Chemicals</b>	<b>Notes</b>
Sealant	3M Ultra-Pro Body Sealant
Simple Green All Purpose Cleaner or equivalent	1/2 strength

**General Applicability**

All iA models
---------------

**Recommended Sequence of Application**







Item #	Accessory
1	
2	
3	

\*Mandatory

**Vehicle Service Parts** (may be required for reassembly)

Item #	Quantity Req.	Description
1		
2		
3		

**Legend**

	<b>STOP:</b> Damage to the vehicle may occur. Do not proceed until process has been complied with.
	<b>OPERATOR SAFETY:</b> Use caution to avoid risk of injury.
	<b>CAUTION:</b> A process that must be carefully observed in order to reduce the risk of damage to the accessory/vehicle and to ensure a quality installation.
	<b>TOOLS &amp; EQUIPMENT:</b> Used in Figures calls out the specific tools and equipment recommended for this process.
	<b>REVISION MARK:</b> This mark highlights a change in installation with respect to previous issue.
	<b>SAFETY TORQUE:</b> This mark indicates that torque is related to safety.

Care must be taken when installing this accessory to ensure damage does not occur to the vehicle. The installation of this accessory should follow approved guidelines to ensure a quality installation.

These guidelines can be found in the "Accessory Installation Practices" document.

This document covers such items as:-

- Vehicle Protection (use of covers and blankets, cleaning chemicals, etc.).
- Safety (eye protection, rechecking torque procedure, etc.).
- Vehicle Disassembly/Reassembly (panel removal, part storage, etc.).
- Electrical Component Disassembly/Reassembly (battery disconnection, connector removal, etc.).

Please see your Toyota dealer for a copy of this document.

### 1. Prepare for the Installation.

- (a) The deck lid and spoiler should be a minimum of 60°F (16°C) for proper set-up of adhesive tape. Use a hot air blower to heat the surface if the temperature is below 60°F (16°C).
- (b) Verify the kit contents (Fig. 1-1).
  - (1) Spoiler assembly
  - (2) M6 Flange Nut (x2)
  - (3) M6 Serrated Flange Bolt (x2)
  - (4) Torsion Bar Bracket (x2)
- (c) Ensure all application areas are free from dirt and debris.
- (d) Clean the area of application with ½ strength Simple Green or similar cleaning agent.
- (e) Use a panel removal tool to remove all 13 buttons and the trunk liner (Fig. 1-2). Retain the liner and buttons for reinstallation.

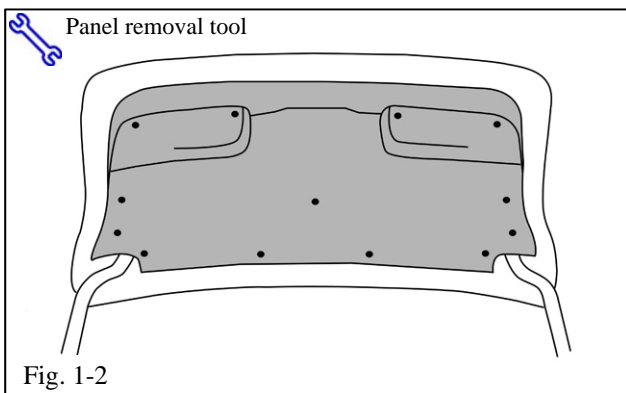
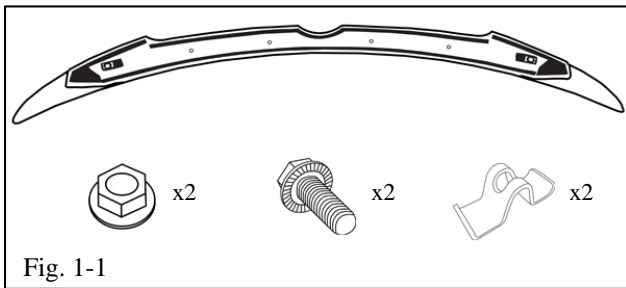

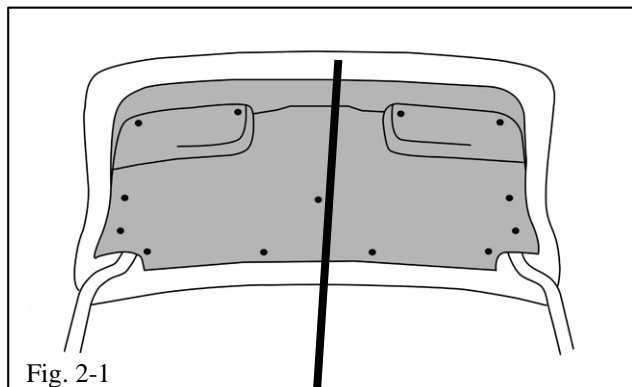

Fig. 2-1

## 2. Install the Torsion Bar Bracket.

- ⚠ (a) Open the trunk fully and use a support bar to keep the trunk lid from closing during installation (Fig. 2-1).

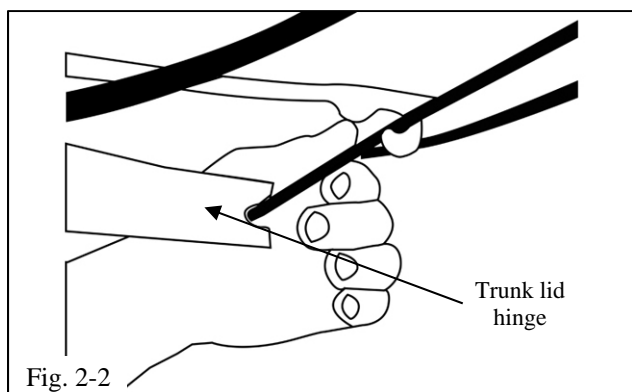

Fig. 2-2

- (b) Carefully push down the torsion bar and release it from the trunk lid hinge (Fig. 2-2 & Fig. 2-3).

⚠ **NOTE:** Both sides need to be prior to spoiler installation.

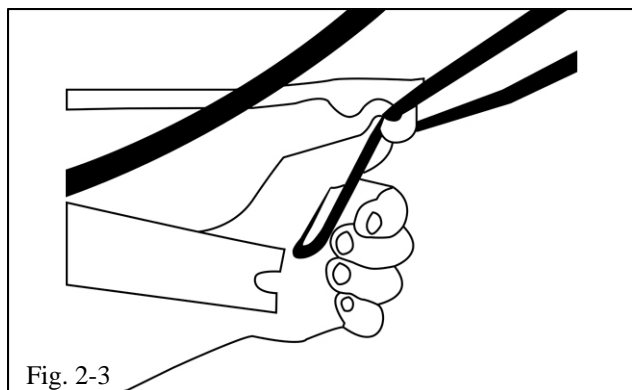
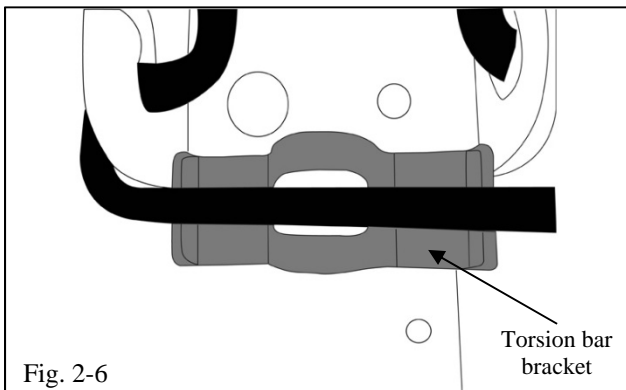
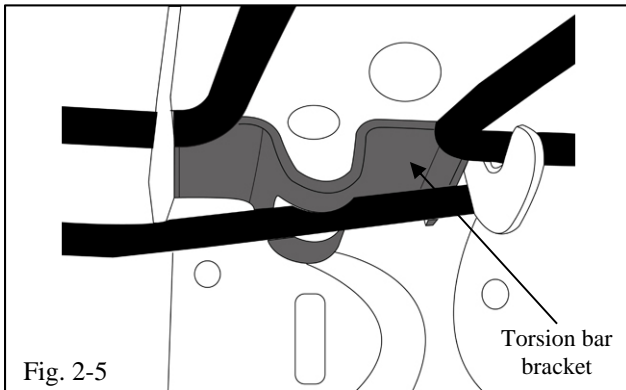

Fig. 2-3



Fig. 2-4

- (c) Install the torsion bar bracket in the factory location. Slightly pull down the torsion bar to fit the bracket into location (Fig. 2-4).
- (d) Repeat the assembly of the torsion bar on the other side.
- (e) Reload the torsion bar onto the trunk lid hinges on both sides.



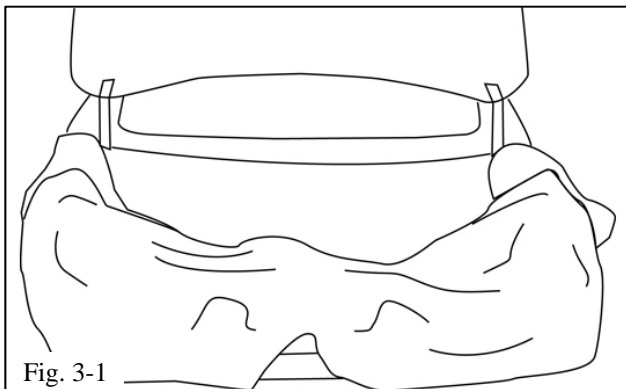

- (f) Check the torsion bar bracket to ensure it is properly seated (Fig. 2-5 & Fig. 2-6).

### 3. Install the Spoiler.

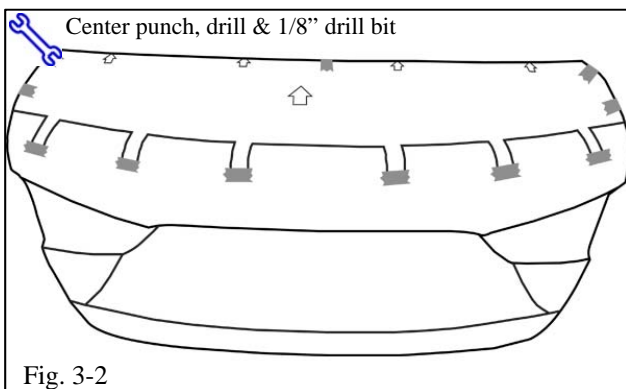

- (a) Protect the vehicle by placing a blanket or other covering around the trunk area (Fig. 3-1).



- (b) Place the drill template onto the deck lid and carefully tape it into position using the sequence stated on the template (Fig. 3-2).
-  (c) Use a center punch to mark the locations of the six holes to be drilled. Remove the template.
- (d) Use a 1/8" bit to drill pilot holes in all six locations.

 **CAUTION:** Wear safety glasses when drilling.

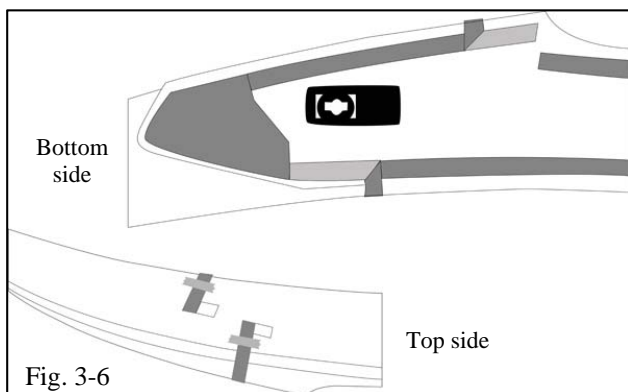
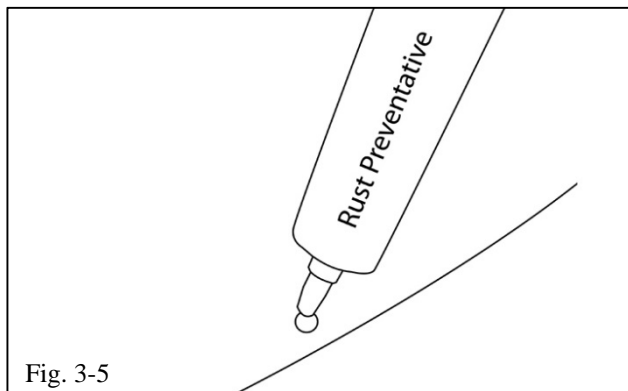
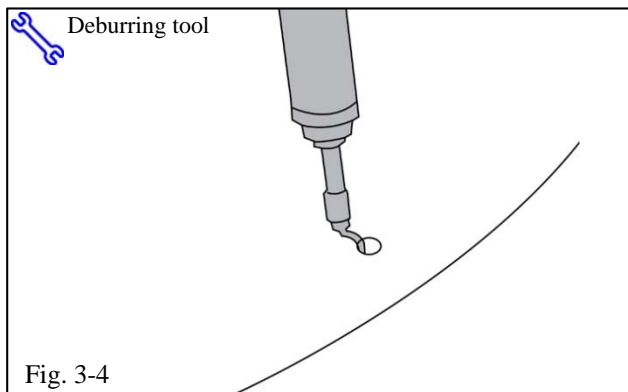
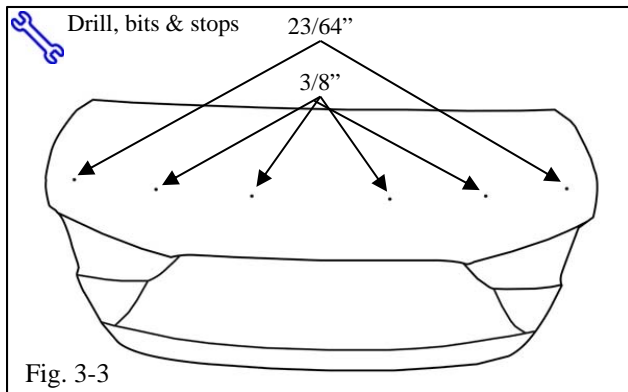

- ⚠ (e) Use a 23/64" bit with a drill stop set to 1" to enlarge the outer two holes (Fig. 3-3).
- ⚠ (f) Use a 3/8" bit with a drill stop set to 1" to enlarge the inner four holes (Fig. 3-3).

- ⚠ (g) Deburr the drilled holes (Fig. 3-4). Vacuum all shavings as well as the work place after drilling.
- ⚠ (h) Dry fit the spoiler to the deck lid. Make sure the spoiler is aligned equally on both sides of deck lid.

- ⚠ (i) Apply 3M Ultra PRO Body Sealant to the drilled holes (Fig. 3-5).

- (j) Locate all of the pull tab locations on the release liners. Peel back 1/4" - 1/2" of release liner, fold it over and tape it to the top of the spoiler (Fig. 3-6).
- (k) Remove both release liners from the die cut end pieces.

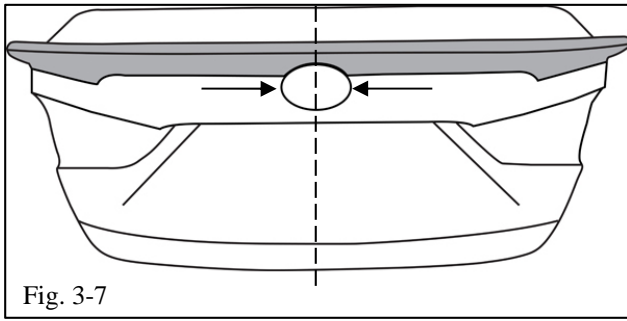

Fig. 3-7

- ⚠ (l) Prior to pulling the remaining tape liners, center the spoiler on the deck lid, making sure that the crescent of the spoiler fits evenly around the oval logo (Fig. 3-7).

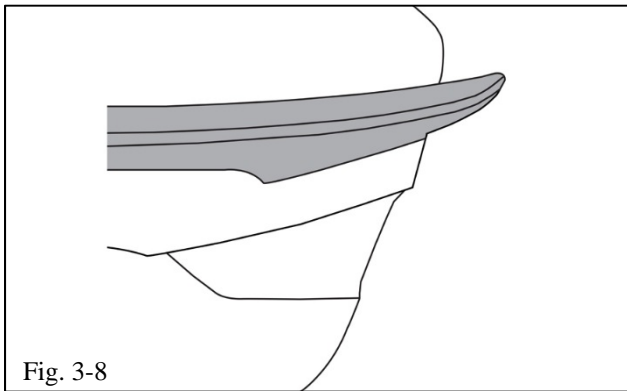

Fig. 3-8

- ⚠ (m) Firmly push down on the ends of the spoiler to engage the end clips (Fig. 3-8).
- (n) Loosely install and hand tighten each nut and bolt.

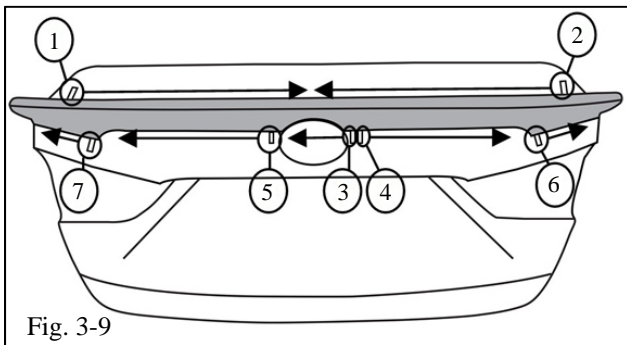

Fig. 3-9

- (o) Reconfirm the positioning of the spoiler on the deck lid. Gently pull the release liner tape in the order and the direction indicated in Fig. 3-9.

⚠ **NOTE:** Pull the tape liner and not just the release liner tab.

- ⚠ (p) Firmly press down from the center out to ensure proper tape adhesion.

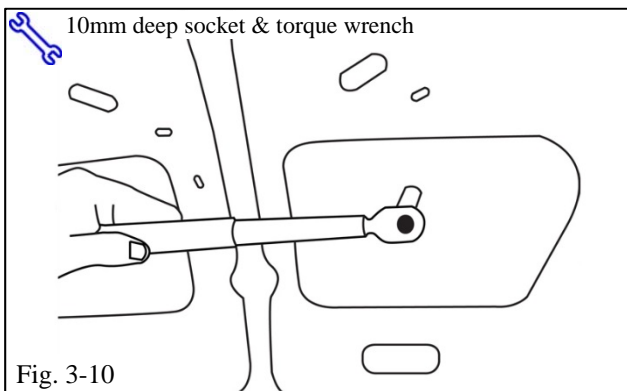

Fig. 3-10

- (q) Torque all hardware to 6 N-m (53 in-lbf), starting with the two inner studs working out (Fig. 3-10).

⚠ **Torque: 6 N-m (53 in-lbf)**

- (r) Reinstall the trunk liner with the retained buttons.
- (s) Do a final clean-up around the spoiler.

Checklist - these points **MUST** be checked to ensure a quality installation.

Check:	Look For:
<p><u>Accessory Function Checks</u></p> <ul style="list-style-type: none"> <li><input type="checkbox"/> Check for visual alignment</li> <li><input type="checkbox"/> Check for full tape adhesion</li> <li><input type="checkbox"/></li> <li><input type="checkbox"/></li> </ul>	<p>The spoiler should be centered side to side (+/- 2.0 mm at ends)</p> <p>Full adhesion of tape with no gaps</p>
<p><u>Vehicle Function Checks</u></p> <ul style="list-style-type: none"> <li><input type="checkbox"/> Trunk lid opens with trunk release lever</li> <li><input type="checkbox"/> When opened fully, the trunk lid remains open on its own</li> <li><input type="checkbox"/></li> </ul>	<p>Confirm that the trunk lid will pop open when the trunk lid release is used</p> <p>When fully opened, the trunk lid must not close under its own weight</p>
<p><u>Vehicle Appearance Check</u></p> <ul style="list-style-type: none"> <li><input type="checkbox"/> After accessory installation and removal of protective cover(s), perform a visual inspection.</li> </ul>	<p>Ensure no damage (including scuffs and scratches) was caused during the installation process. (For PPO installations, refer to TMS Accessory Quality Shipping Standard.)</p>