

Section I - Installation Preparation

Part Number: PT329-34100

Section I - Installation Preparation

Kit Contents

Item #	Quantity Req'd.	Description
1	1	Curved Tube Assembly - Right
2	1	Curved Tube Assembly - Left
3	3	Center Tube
4	1	Hardware Bag

Hardware Bag Contents

Item #	Quantity Req'd.	Description
1	6	Thin Wedge
2	6	Thick Wedge
3	6	PT Screw

Additional Items Required For Installation

Item #	Quantity Req'd.	Description
1	1	PT329-35101-Tacoma Bracket Kit
2	1	PT329-34101-Tundra Bracket Kit

Conflicts

Note: Bed Mat

Recommended Tools

Safety Tools	
Safety Glasses	
Special Tools	
None	
Installation Tools	
Tape Measure	
Torque Wrench	For Torx and Philips Bits
Rubber Mallet	Small
Screwdriver	Torx T-20
For Tundra	
Screwdriver	Torx T-40
Hex Key	4 mm
For Tacoma	
Screwdriver	Philips, #3
T-handled Driver	
Utility Knife	For pre-MY2000 only.
Special Chemicals	
Cleaner	3M™ Prep Solvent-70

General Applicability





Tacoma - Short and long bed, MY1997 to present. Tundra - Short and long bed, MY2000 to present.

Recommended Sequence of Application

Item #	Accessory	
1		
2		
3		

*Mandatory

Legend

	STOP: Damage to the vehicle may occur. Do not proceed until process has been complied with.
	OPERATOR SAFETY: Use caution to avoid risk of injury.
	CRITICAL PROCESS: Proceed with caution to ensure a quality installation.
	GENERAL PROCESS: This highlights specific processes to ensure a quality installation.
	TOOLS & EQUIPMENT: Calls out the specific tools and equipment recommended for this process.

Section II - Installation Procedure

A. Install Mounting Brackets

1. If bedliner is installed, use a #3 Philips Screwdriver to loosen the bedliner bolts nearest to the tailgate.

NOTE: Some bedliners are mounted using T-20 Torx bolts, and some (under-the-rail) have no hardware.

2. Using the appropriate tool (T-40 Torx or #3 Philips), remove the two bolts that attach the right (passenger side) cargo tie-down loop to the body (Fig. A-1).

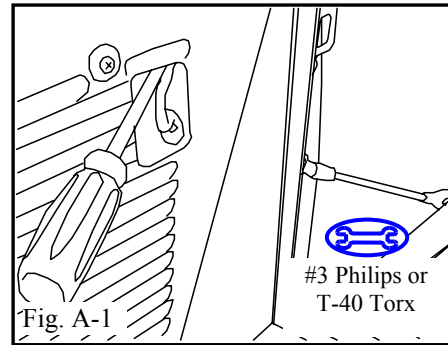

3. While flexing the bedliner to allow a sufficient gap (not to exceed 154mm or 6 in.) between bedliner and truck bed, position the mounting bracket onto the truck bed (Fig. A-2), if applicable.

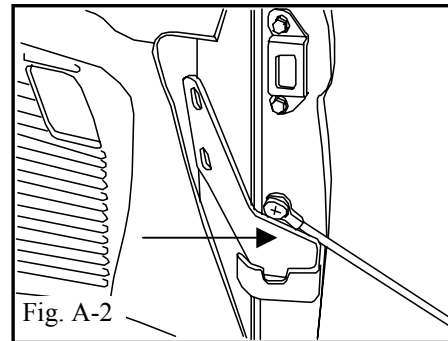

- i. The mounting section of bracket will be positioned underneath the bedliner while the pivot section will be on top of the bedliner.



- ii. Be careful not to scratch the vehicle.

4. Using the appropriate tool (T-40 Torx or #3 Philips), bolt down mounting bracket using OE tie-down loop and the provided bolts. (Fig. A-3).

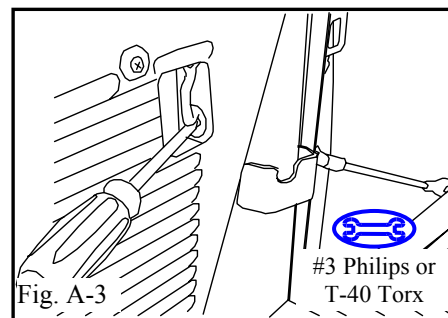

- i. Tighten fasteners to following torque to the following torques.

Tundra: 17.5 N-m (156 lbf-in.)

Tacoma: 11.5 N-m (102 lbf-in.)



- ii. The slotted mounting holes to the bracket allow an adjustment to the height of the bracket, high for trucks with a bedliner and low for trucks without (Fig. A-4).

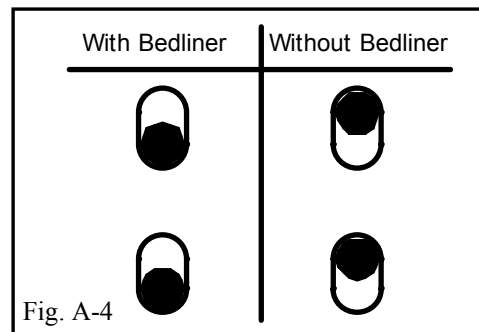

Section II - Installation Procedure

5. Retighten the bedliner bolts (if applicable) that were loosened in Step A. 1..
6. Repeat procedure (Steps A. 2. to A. 5.) for the left (driver's side) cargo tie-down loop and the left mounting bracket.

B. Minor Modification for Pre-MY2000 - Tacoma

NOTE: If a Pre-MY2000 Bedliner is used, some minor modifications will be required to the Bedliner prior to installing the Bed Extender Brackets.

1. The bedliner should be cut with an utility knife as shown in Fig. B-1, to allow for proper clearance for installing the Bed Extender Brackets.

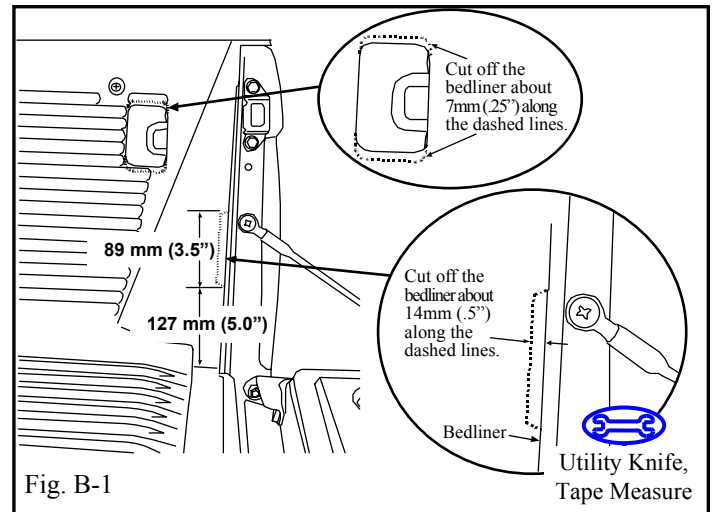

C. Assemble and Install Bed Extender

1. Loosely join the center tubes to the right tube section, then the left tube section, as shown, beyond the non-powder coated sections (Fig. C-1).

i. Do not allow bare metal to be exposed.

2. Adjust the bed extender assembly width by sliding the right/left tube sections in or out on the center tubes so that the assembly can drop down vertically into the mounting brackets as shown in Fig. C-2.

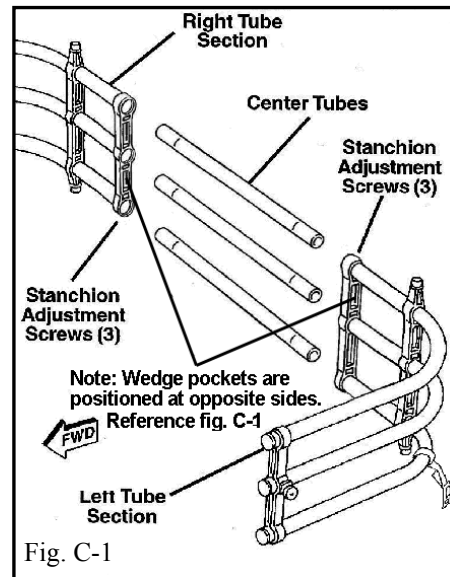

i. Make sure that the two straps are facing rearward.

D. Positioning of Center Tube Stanchions

1. Rotate the assembly onto the open tailgate.

NOTE: It is normal for the Bed Extender to have some resistance, when it is first rotated in the bracket.

2. Move the right center stanchion over the right tube section by tapping with a rubber mallet.

i. Be careful not to scratch the center tubes.

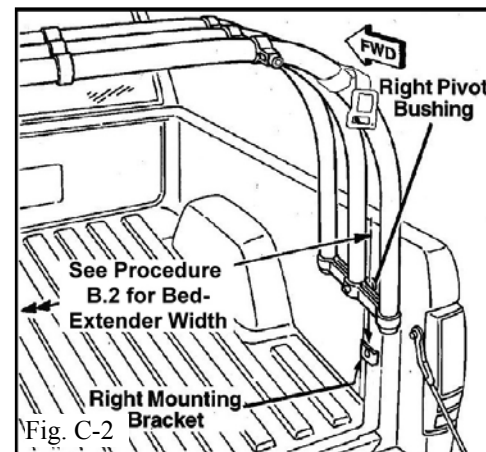

Section II - Installation Procedure

- STOP
 - ii. Excessive force may damage extender and/or vehicle.
- 3. Insert wedges into the three (3) wedge pockets of stanchion on both sides of the each stanchion (Fig. D-1).
- STOP
 - i. The thinner wedges face the center of the Bed Extender.
- 4. Insert three (3) stanchion adjustment screws from center of Bed Extender.
- 5. With a T-20 Torx wrench, tighten the three (3) screws after stanchion is securely in place to 2.3 N-m (20 lbf-in.).
- 6. Repeat steps D. 2. through D. 5. for the other (left) center stanchion.

E. Adjustment of Locking Straps

FOR TUNDRA VEHICLES ONLY.

(Steps E. 1. and E. 2.)

- ➔
 - 1. Attach nylon insert to locking strap buckle with M5 bolt, nylon insert facing inward (2.3 N-m or 20 lbf-in.). (Fig. E-1)
 - 2. Install Anti-Chip Tape onto tailgate latch area as shown in Fig. E-2.
 - i. Clean surface before installing Anti-Chip Tape using 3M™ Prep Solvent-70.
 - ➔
 - ii. When cleaning with 3M™ Prep Solvent-70 follow the manufacturer's directions. Do not allow cleaner to air dry
- ➔
 - 3. Adjust strap length and position, in order to allow locking strap buckles to lock into tailgate.
 - STOP
 - i. When the Extender is in the inward position, clip the straps onto the Strap Latch Retainer as shown in Fig. E-3. This will prevent the buckles from rattling.

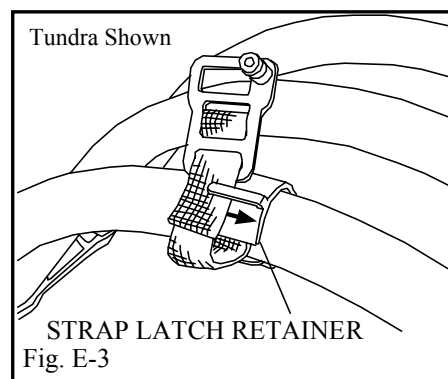
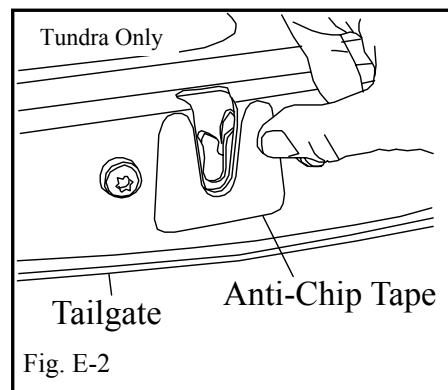
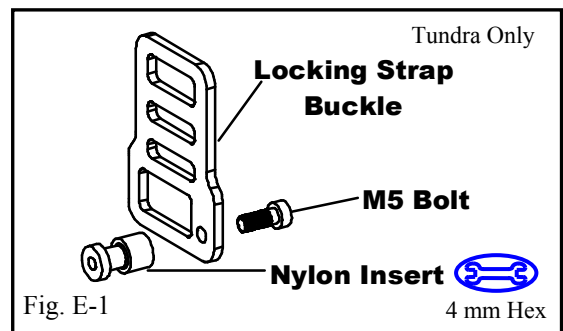
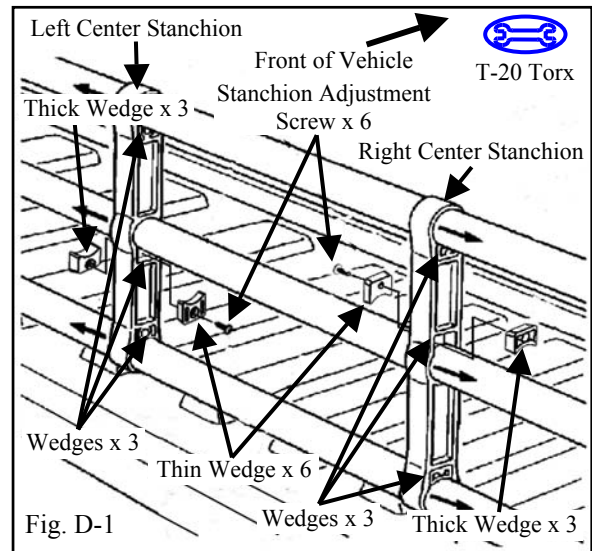



Section III - Functional Verifications

Check: _____

- Bed extender adjustment.
- Tailgate strap adjustment.
- Torque adjustment of stanchion screws.
- Torque adjustment of bracket mounting bolts.
- Upright foot positioning on tailgate.

Look For: _____

Bed extender pivot point must rest in mounting brackets.

Tailgate straps must be able to lock into tailgate locks.

Stanchion screws must be tightened to 2.3 N-m (20 lbf-in.).

Bracket mounting bolts must be tightened to:

Tundra: 17.5 N-m (156 lbf-in.)

Tacoma: 11.5 N-m (102 lbf-in.)

Ensure that upright feet sit properly on tailgate edge